

Movopart CB

Installation and service manual



Table of Content

| | |
|--|-----------|
| Section 1 Introduction | 2 |
| Section 2 Type designation system | 3 |
| Section 3 Installation | 4 |
| 3.1 Mounting instructions..... | 4 |
| 3.2 Connection to motor flange..... | 5 |
| 3.3 Connection to saddle | 5 |
| Section 4 Service and maintenance | 6 |
| 4.1 General maintenance instructions | 6 |
| 4.2 Lubrication | 6 |
| 4.3 Control and adjustment of belt tension..... | 7 |
| 4.4 Control and adjustment of belt position..... | 8 |
| 4.5 Control and adjustment of saddle play..... | 9 |
| Section 5 Technical data | 10 |

Section 1 Introduction

Movopart CB is a linear drive unit built around an extruded aluminium profile with a drive station in one end and a tension station in the other. Along the profile there is one or several moving saddles to which the load is connected. There is a belt running through the profile and over the both stations. The belt is driven by a motor, which is mounted to the drive shaft of the drive station. This enables the motion of the saddle. Rollers are mounted inside the saddle for guidance along the shafts on each side of the profile. Movopart CB is available in a number of different configurations, which are described in the type designation key on the next page.

In order to be able to use this manual properly, it is important to understand which type of Movopart CB you have. Feel free to contact Tollo Linear if there are any doubts as to the type or if you have any other questions. When you do so, please state the manufacturing number and the type designation of the Movopart CB. See figure 1.

Important!

- Read through this manual before beginning the installation or servicing and follow all applicable directions in order to ensure a safe and proper job.
- In order to ensure a long life expectancy and reliable functionality, Movopart CB must be serviced according to the directions found in this manual. Spare parts should be by the same manufacturer and of the same type as the original or be among those approved in writing by Tollo Linear. Never use parts which work improperly or seems damaged.
- The system or machine part of which Movopart CB is a component must not be used before it is in compliance with the EU's Machinery Directive in those instances where it is to be used within the EEC area.
- If possible, never work with power, compressed air or hydraulics turned on. If the work must be performed with some of these turned on, another person must be positioned so that the power, compressed air or hydraulics can be turned off in the event of any mishap.

Section 2 Type designation system

| | M | R | -C | B | 200 | A | 00 | X | ... |
|--|---|---|----|---|-----|---|----|---|-----|
| Metric.....M | | | | | | | | | |
| Roller guide.....R | | | | | | | | | |
| Profile size.....CB.....-C | | | | | | | | | |
| Belt drive.....B | | | | | | | | | |
| Linear move / drive shaft revolution.....200 mm.....200 | | | | | | | | | |
| Single saddle.....A | | | | | | | | | |
| Double saddles.....C | | | | | | | | | |
| Standard at single saddle.....00 | | | | | | | | | |
| Lc (c/c distance between double saddles in cm).....35 - 99 | | | | | | | | | |
| Drive shaft on both sides.....X | | | | | | | | | |
| Drive shaft on left side.....Q | | | | | | | | | |
| Drive shaft on right side.....R | | | | | | | | | |
| or at | | | | | | | | | |
| Movopart CB with custom design.....M | | | | | | | | | |
| Order length in cm (see measure L in figure 1).....000 – 999 | | | | | | | | | |
| or | | | | | | | | | |
| Sequential number at custom design.....000 – 999 | | | | | | | | | |

Table 1: Type designations

Section 3 Installation

3.1 Mounting instructions

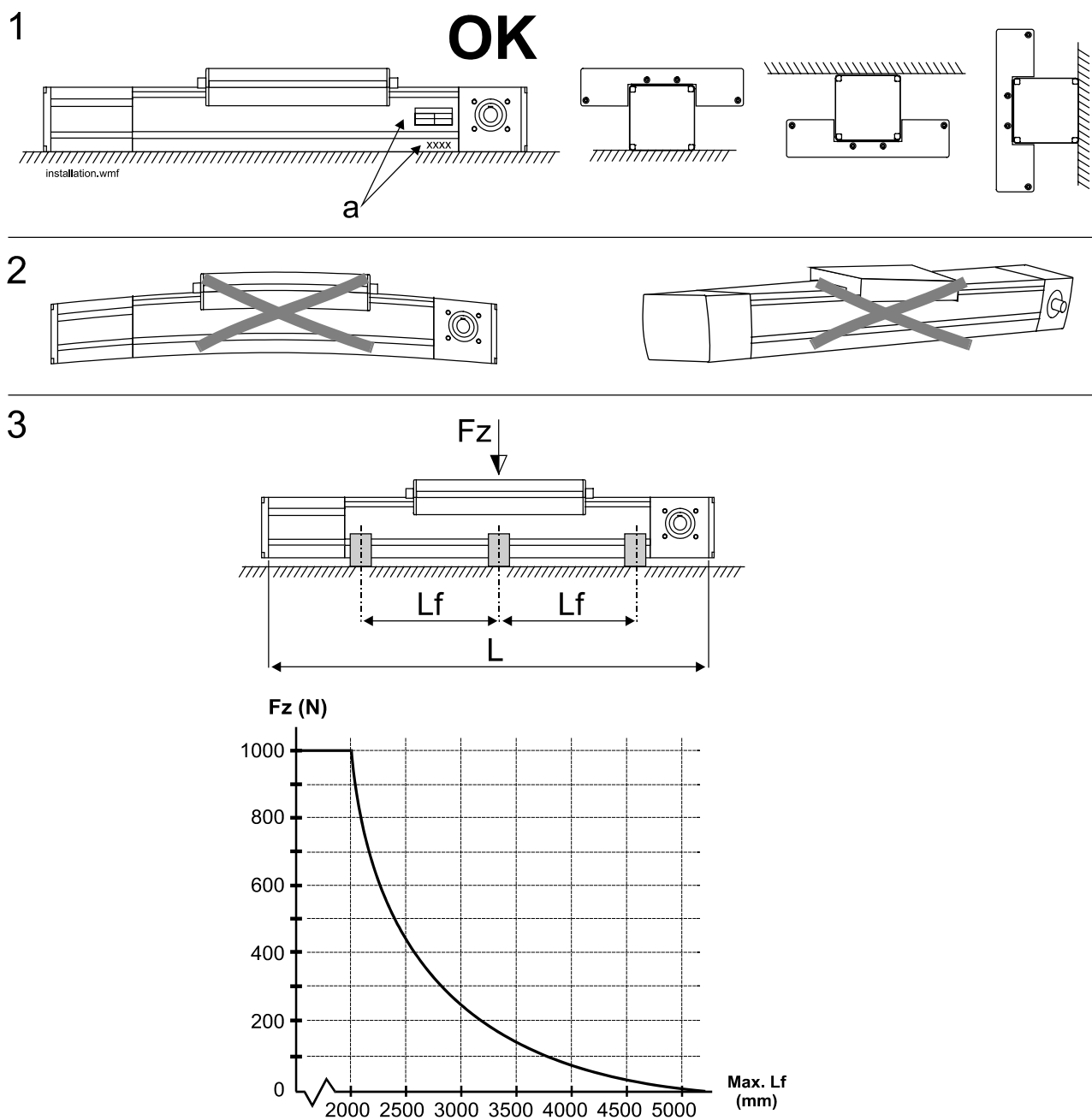

Figure 1: Mounting instructions

1. The unit can be mounted towards the support in any rotational direction. State the manufacturing number and the type designation of the unit (a) at spare part ordering.
2. The unit may not be mounted so that it is exposed to any bending or twisting forces.
3. Place the unit on the mounting surface. Place shims at the mounting points so that the unit keeps its shape and is not bent or twisted in any direction. The distance between each mounting point must not exceed the max. permissible mounting distance (Max. Lf) for the max. load being moved (Fz) by the unit. After the mounting, check the belt position, see point 4.4.

3.2 Connection to motor flange

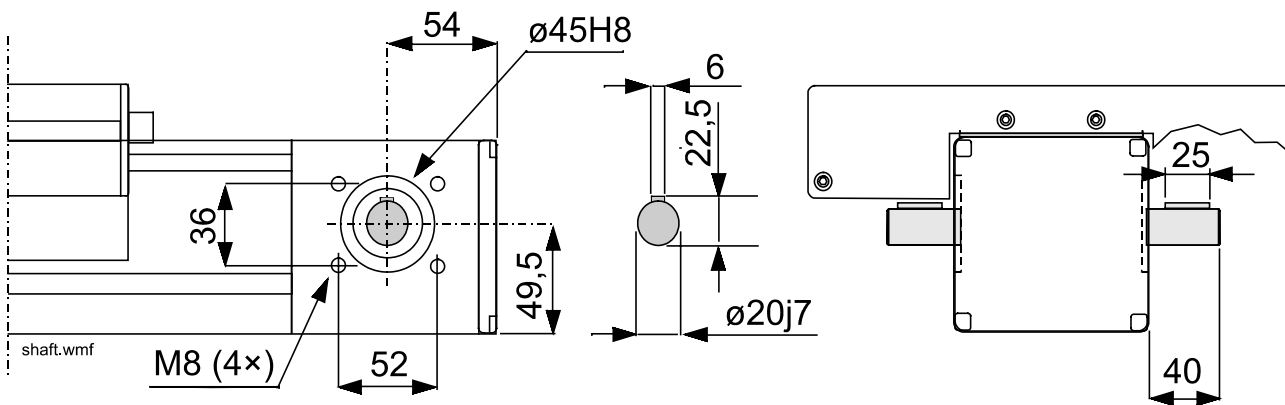

Figure 2: Connection to motor flange

3.3 Connection to saddle

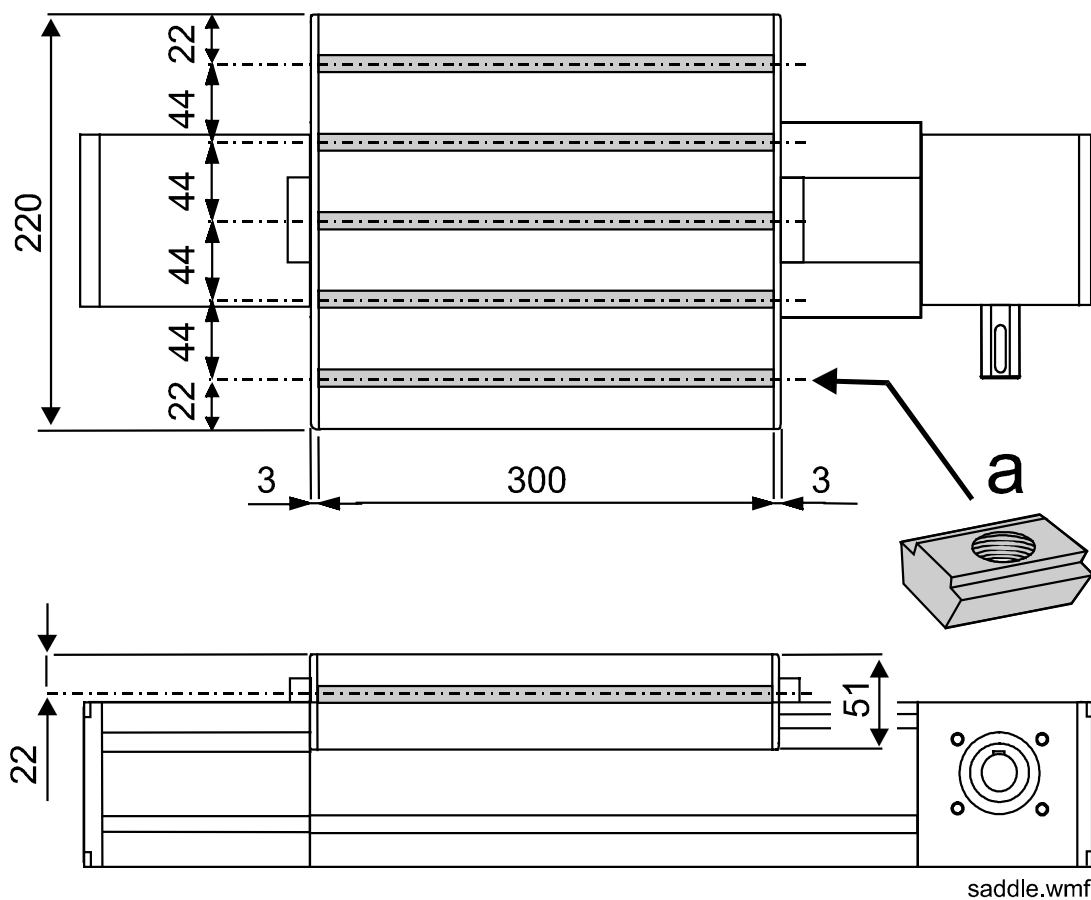

Figure 3: Saddle dimensions

The load is attached to the saddle by using the T-slots and T-slot nuts (a).

| T-slot nuts | p / n |
|-------------|----------|
| M6 | D900 151 |
| M8 | D900 150 |

Table 2: T-slot nuts

Section 4 Service and maintenance

4.1 General maintenance instructions

- The customer can perform the service and maintenance described in this manual. Other service ought to be performed by service personnel from Tollo Linear, either on-site or at a Tollo Linear Service Centre.
- Follow the recommended service intervals. Replace defective parts immediately. Only use parts of the same make and type as original. Ordering data can be found in the spare part lists supplied with the unit. Also state the manufacturing number of the unit (see figure 1).
- Movopart CB is not self-braking. This means that the load can move if the driving force is disconnected, or if the motor, gears or brakes are detached during service. This is even more important for vertical applications. Ensure therefore that the load is secured before service.
- Check the unit in connection to lubrication. Particularly check for wear or damage on the belt, the suspensions and the connection of the load. Also be attentive towards a changed level of noise. Replace, repair or adjust.
- Keep the unit clean. Wipe it off as required. If cleaning fluid is required, use small amounts and see to it that none gets into Movopart CB, do not use strong cleaning agents. Dry it fully.
- **Never** mix different types of oils / lubricants!

4.2 Lubrication

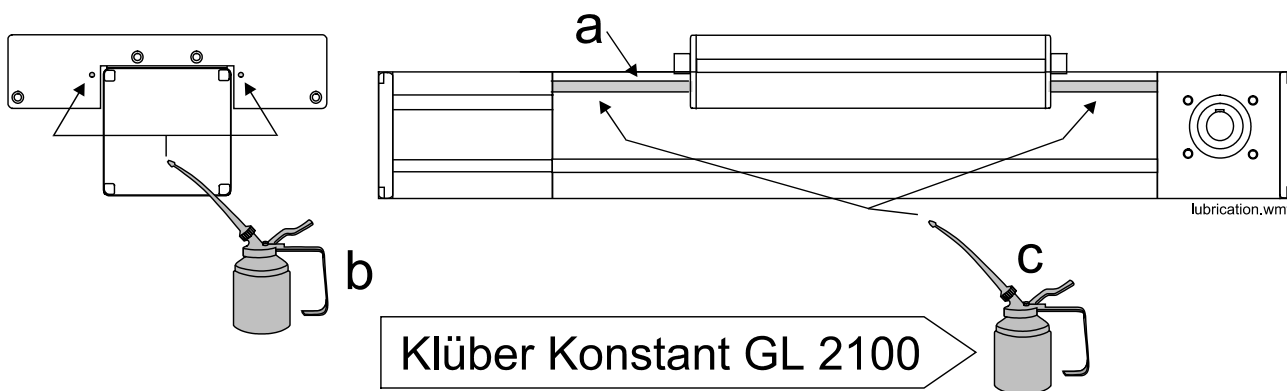

Figure 4: Lubrication

The steel shafts (a) must always be coated with a thin layer of oil. Apply oil to the lubrication pads in the saddle through the lubrication holes (b) (two holes on each side) or directly on to the shafts (c) when needed. Use oil of type Klüber Konstant GL 2100.

4.3 Control and adjustment of belt tension

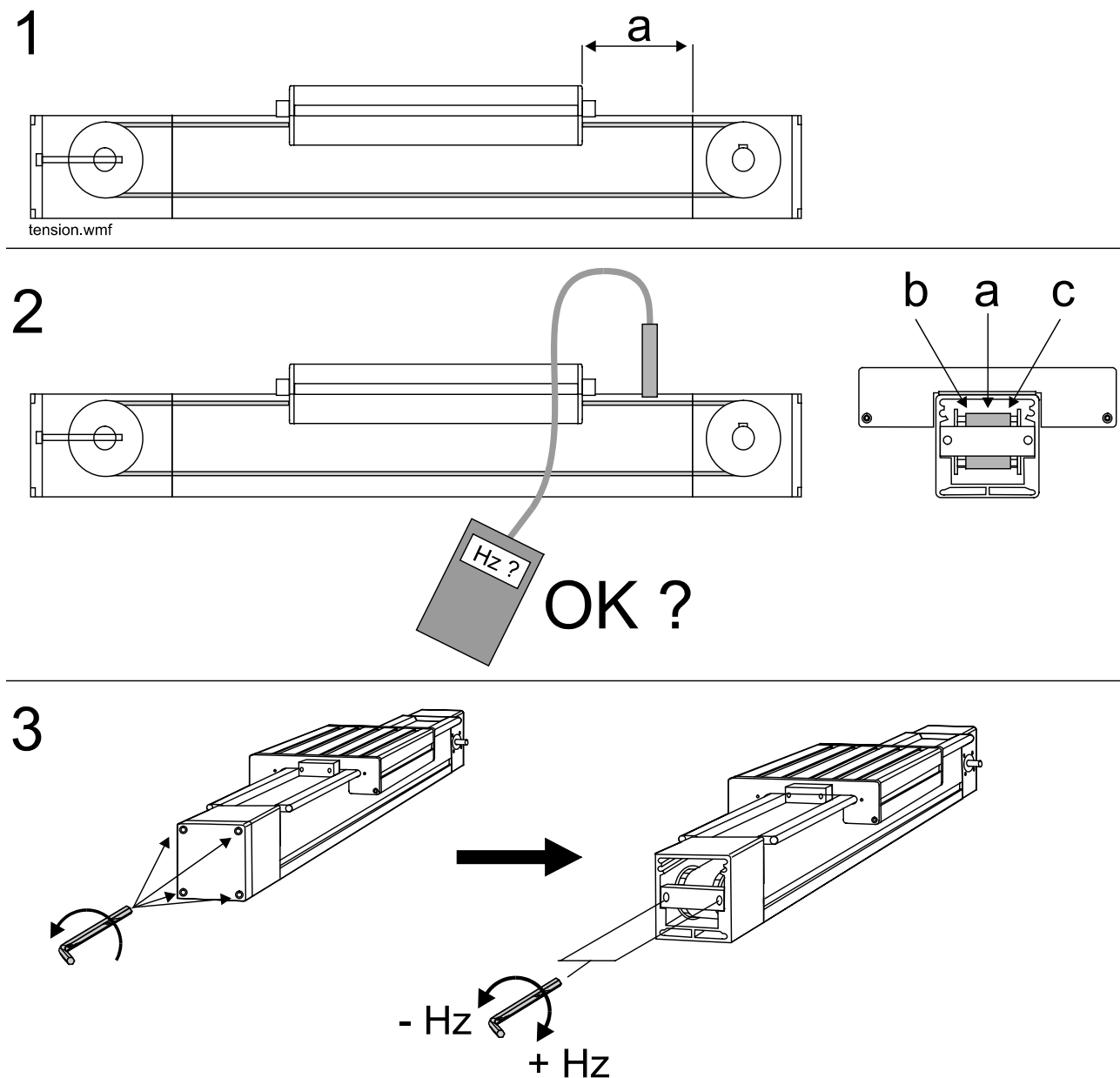

Figure 5: Adjustment of belt tension

1. Place the saddle at 110 mm (distance a) from the drive station.
2. Measure the belt frequency with a frequency meter according to the instruction of the frequency meter being used. Correct frequency is $215 \text{ Hz} \pm 10$. Measure so that the frequency is correct both in the middle (a) and at the sides of the belt (b and c).
3. If the frequency is not correct, remove the end cover and turn the adjustment screws until the correct frequency is set. Keep in mind that the tension station must not be moved out of position when the fixing screws for the end cover and the tension station are removed. After completion of the belt tension adjustment, check so that the belt position is correct. See point 4.4.

4.4 Control and adjustment of the belt position

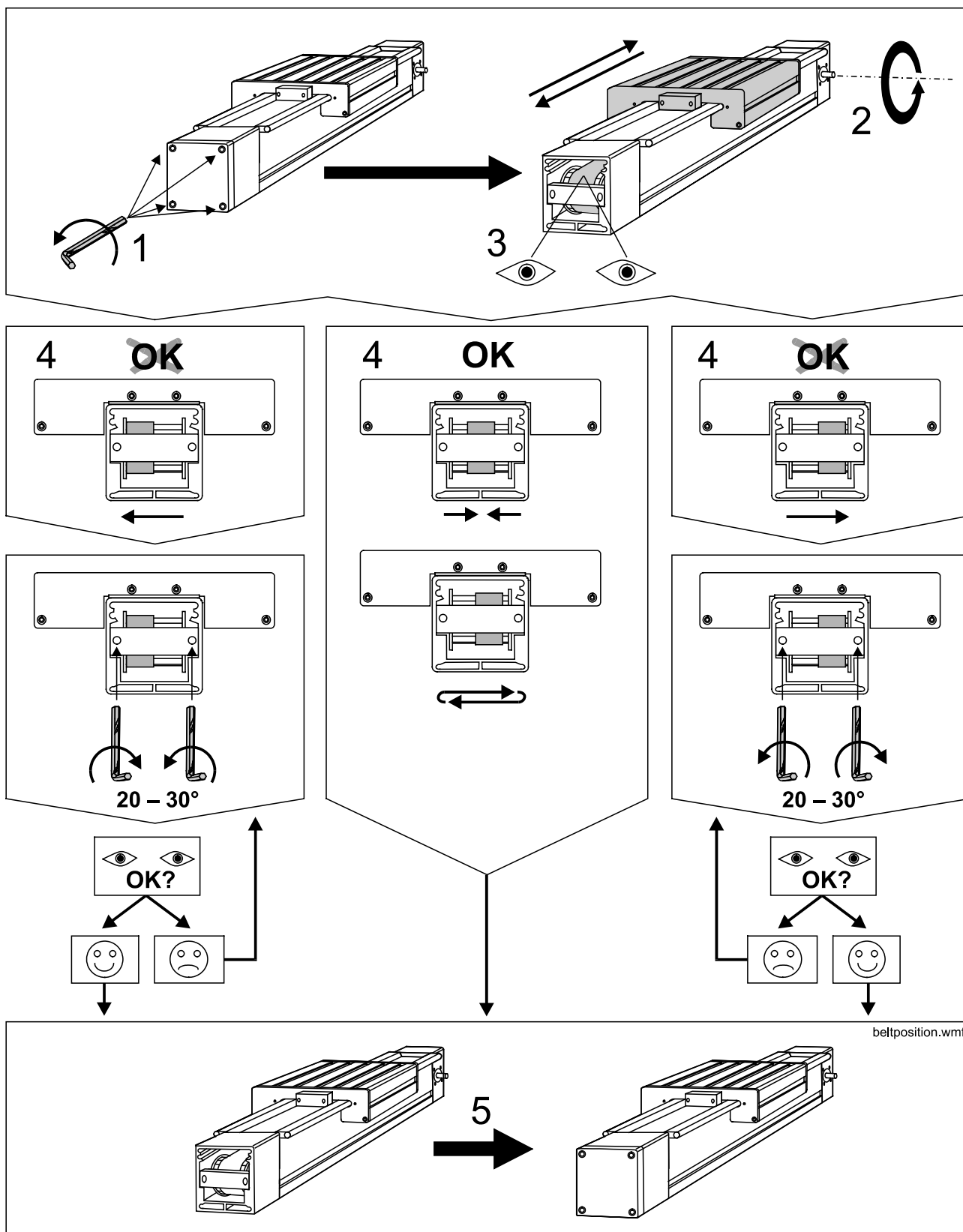

Figure 6: Adjustment of belt position

Check the belt position after installation or a belt replacement. The belt shall during operation lie in the centre or wander from side to side of the tension pulley, otherwise adjust. Check the belt tension before any adjustment, see point 4.3. Keep in mind that the saddle must move back and forth during the check and that the tension station must not be moved out of position when the fixing screws for the end cover and the tension station are removed. Turn the adjustment screws max. 20 – 30° and check, repeat until position is correct.

4.5 Control and adjustment of saddle play

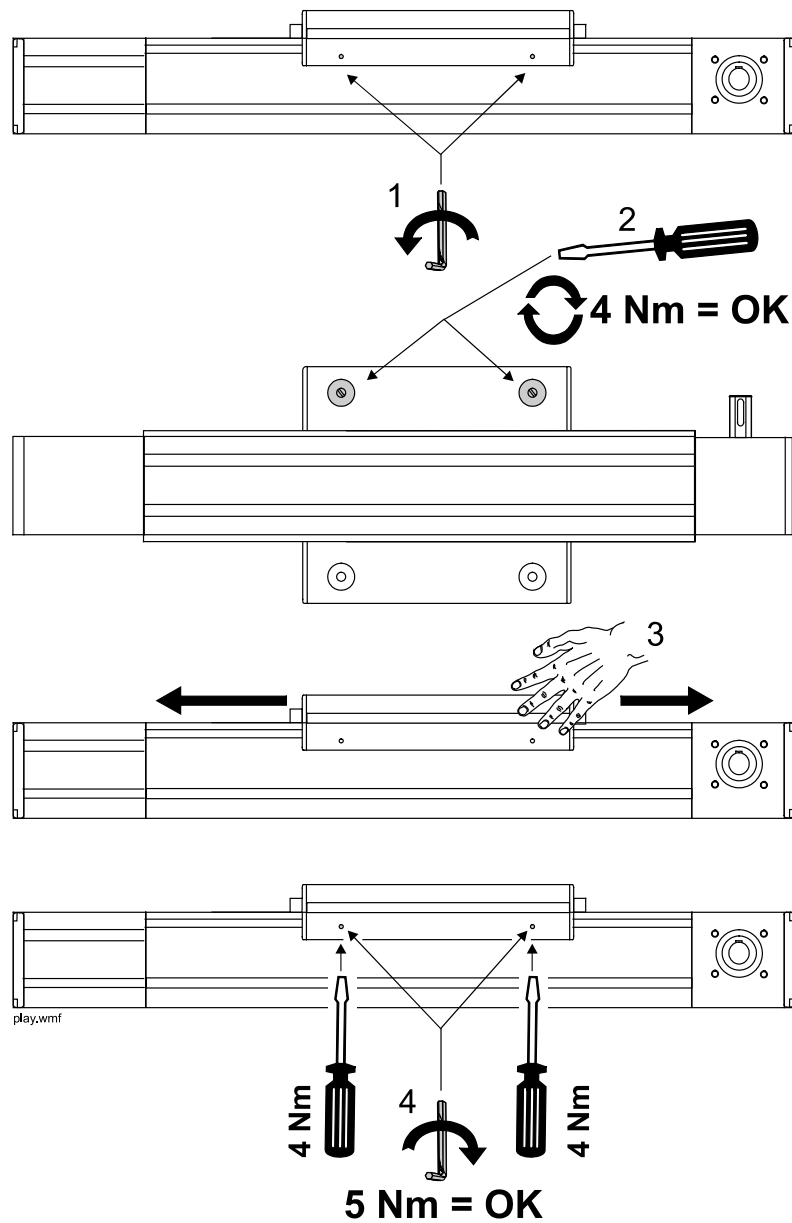

Figure 7: Adjustment of saddle play

1. Loosen the lock screws.
2. Turn the adjustment screws until each screw has a torque of 4 Nm.
3. The saddle shall move under slight pressure, which not varies, when it is moved along the profile.
4. When the saddle play is correct, tighten the lock screws with a torque of 5 Nm. During the tightening of the lock screws a torque of 4 Nm should be applied on the adjustment screws.

Section 5 Technical data

| Movopart CB | | MR-CB |
|--------------------------------------|-------|---------------------------|
| Max. speed | (m/s) | 5 |
| Repeatability | (mm) | ± 0,1 |
| Ambient temperature | (°C) | -20 – +70 |
| Linear move / drive shaft revolution | (mm) | 200 |
| Max. input speed | (rpm) | 1500 |
| Weight at single saddle | (kg) | $7,8 + (L^A \times 8,2)$ |
| Weight at double saddle | (kg) | $12,2 + (L^A \times 8,2)$ |

^AL in meter, see figure 1

Table 3: Technical data

– Page intentionally left blank –

EUROPE**United Kingdom**

Thomson
Office 9, The Barns
Caddsdow Business Park
Bideford
Devon, EX39 3BT
Phone: +44 (0) 1271 334 500
E-mail: sales.uk@thomsonlinear.com

Germany

Thomson
Nürtinger Straße 70
72649 Wolfschlugen
Phone: +49 (0) 7022 504 0
Fax: +49 (0) 7022 504 405
E-mail: sales.germany@thomsonlinear.com

France

Thomson
Phone: +33 (0) 243 50 03 30
Fax: +33 (0) 243 50 03 39
E-mail: sales.france@thomsonlinear.com

Italy

Thomson
Largo Brughetti
20030 Bovisio Masciago
Phone: +39 0362 594260
Fax: +39 0362 594263
E-mail: info@thomsonlinear.it

Spain

Thomson
E-mail: sales.esm@thomsonlinear.com

Sweden

Thomson
Estridsväg 10
29109 Kristianstad
Phone: +46 (0) 44 24 67 00
Fax: +46 (0) 44 24 40 85
E-mail: sales.scandinavia@thomsonlinear.com

SOUTH AMERICA**Brazil**

Thomson
Av. Tamborê, 1077
Barueri, SP – 06460-000
Phone: +55 (11) 3616-0191
Fax: +55 (11) 3611-1982
E-mail: sales.brasil@thomsonlinear.com

USA, CANADA and MEXICO

Thomson
203A West Rock Road
Radford, VA 24141, USA
Phone: 1-540-633-3549
Fax: 1-540-633-0294
E-mail: thomson@thomsonlinear.com
Literature: literature.thomsonlinear.com

ASIA**Asia Pacific**

Thomson
E-mail: sales.apac@thomsonlinear.com

China

Thomson
Rm 2205, Scitech Tower
22 Jianguomen Wai Street
Beijing 100004
Phone: +86 400 6661 802
Fax: +86 10 6515 0263
E-mail: sales.china@thomsonlinear.com

India

Thomson
c/o Fluke Technologies Pvt. Ltd.
#424, Deodhar Center,
Marol Maroshi Road,
Andheri – E, Mumbai – 400059 India
Phone: +91 22 29207641
E-mail: sales.india@thomsonlinear.com

Japan

Thomson
Minami-Kaneden 2-12-23, Suita
Osaka 564-0044 Japan
Phone: +81-6-6386-8001
Fax: +81-6-6386-5022
E-mail: csjapan@scgap.com

Korea

Thomson
F7 Ilsong Bldg, 157-37
Samsung-dong, Kangnam-gu,
Seoul, Korea (135-090)
Phone: +82 2 6917 5049
Fax: +82 2 528 1456
E-mail: sales.korea@thomsonlinear.com